



IMPACT CORPORATE IDENTITY

Corporate Communications Department
VERSION : @JUNE 2026



Table of Contents

Welcome	2	OUR RESTAURANT CHAINS	21	Advertising Board (VINYL INKJET)	
IMPACT's Brand Identity		▪ Introduction	21	▪ SUMMARY ALL AREA	54
▪ Business Description	3	Restaurants in the area		▪ Lollipop	55
▪ Brand Positioning	3	▪ Chinese Restaurant Group	22	▪ Billboard (Hong Kong Fisherman-Opposite)	56
▪ Brand Attributes	3	▪ Japanese Restaurant Group	23	▪ Billboard (IMPACT CHALLENGER / Loading)	57
▪ Brand Promise	3	▪ International Food/ Flann O'Briens Irish Pub	24	▪ Banner (IMPACT EXHIBITION HALL9 / AMBER)	58
▪ Partnership for Success Culture	3	▪ International Food/ Terazza	25	Advertising LED SCREEN	
▪ VISIONS / MISSIONS	4	▪ International Food/ Retro Bar & Cafe	26	▪ IMPACT FORUM / Entrance 1	59
▪ IMPACT CORE VALUE	5	▪ Thai Food / Thong Lor	27	▪ LINK BRIDGE / THE PORTAL	60
▪ How We Conduct our business	6	▪ Thai Food / Isan @ Arena	28	▪ CUBIC / NOVOTEL	61
		▪ EASE Café	29	▪ ROYAL JUBILEE BALLROOM	62
Key Design Elements		▪ The Coffee Academics	30	▪ THE PORTAL (TOTEM)	63
▪ Logo	7	▪ SIX ZERO	31	▪ IMPACT CHALLENGER SKY ENTRANCE	64
▪ Colour Code	7	▪ FOOD COURT / THAI THAI	32	▪ SKY ENTRANCE / LOBBY	65
▪ Our Brand mark Clear Space	8	▪ FOOD COURT / SKY KITCHEN	33	BANGKOK LAND SIGNAGE	
▪ Minimum size of logo	9	▪ FOOD COURT / FOOD ARENA	34	▪ Advertising Board	66
▪ Logo Colouring	10	Restaurants in the city		Under Link Bridge	
▪ Logo Use Guidelines	11	▪ HEI YIN	35	Billboard P1 Chaeng Wattana-Tiwanon	
▪ Logo Background	12	▪ XIAN YUAN	36	▪ LED	67
		▪ The Coffee Academics	37	P1 PYLON (LED)	
IMPACT'S TYPEFACES		▪ TSUBOHACHI Japanese Restaurant	38	MT02 (LED)	
▪ Typography	13	IMPACT CULINOVA	39	MT02 (VINYL) LBV01, LBV02	
▪ Typography / THAI	14	IMPACT CATERING	40	▪ P1 LONG BOARD (VINYL)	68
▪ Typography / English	15	THE LAKE CLUB	41	HOTELS	
		IMPACT SIGNAGE		▪ NOVOTEL BANGKOK IMPACT	69
STANDARD COMMUNICATION		▪ Introduction	42	▪ IBIS BANGKOK IMPACT	70
▪ Letterhead	16	▪ Directional Signpost	43		
▪ Business Card	17	▪ IMPACT CHALLENGER/ Directional Signpost	44		
▪ Envelope No.9	17	▪ IMPACT EXHIBITION CENTER/ Directional Signpost	45		
▪ Fax	18	▪ IMPACT FORUM / Directional Signpost	46		
▪ Memo	18	▪ Outdoor direction signpost	47		
▪ Letter Form	18	LED Wall and Digital TV (INDOOR)			
▪ E-mail Signature	19	▪ IMPACT CHALLENGER / Lobby Hall2	48		
▪ PowerPoint® Template	20	▪ IMPACT CHALLENGER / Hall 1, Hall 3	49		
		▪ IMPACT CHALLENGER / Digital TV	50		
		▪ IMPACT EXHIBITION CENTER/ Digital TV	51		
		▪ IMPACT FORUM / Digital TV	52		
		▪ IMPACT FORUM / LED Wall	53		



Welcome

This design manual provides policies, procedures, and methods for developing the corporate design. The guidelines have been designed for a simple application and easy understanding, whatever means of communication are used. The guidelines and design specifications have a binding effect on all IMPACT employees and shall act as a general rule applying to the company's internal and external communication. Each individual employee shall strictly adhere to these guidelines. (Only if these specifications have been consistently complied with will the desired uniform appearance be achieved.)



IMPACT'S BRAND IDENTITY

Business Description

We are the integrated venue management offering diversity of events with versatile facilities and services

Brand Positioning

We are a customer Led Venue that offers flexibility, size, and the integration of our facilities all services to deliver one stop and total solutions to our customers.

Brand Attributes

- Proficient Partner
- Passionate Professional
- Progressive Platform
- Personalised Solution

Brand Promise

IMPACT = Value of Place + People

Partnership for Success Culture

Our Partnership for Success Culture is to deliver high value to our partners and customers through mutual trust, cooperation, strategic partnerships, customized and turnkey solutions.

IMPACT'S BRAND IDENTITY

Vision:

We want to be a leading MICE destination in Asia, renowned for hosting world class business and entertainment events, enhancing Thailand's position as the premier and MICE hub.

Mission:

Delivering exceptional products and services to our customers with integrity, professionalism while being a responsible and sustainable corporate citizen to our local community and country.

IMPACT CORE VALUES



INNOVATIVE
MINDSET

กล้าคิด กล้าทำ
กล้าเปลี่ยนแปลง



PARTNERSHIP
FOR SUCCESS

เป็นทีม เป็นหนึ่ง
เป็นพันธมิตร



CUSTOMER
TRUST

ให้ก่อน ให้ใจ
ให้โอกาส

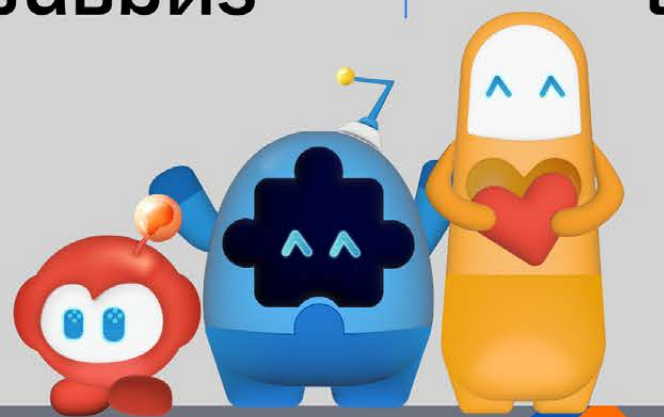

IMPACT'S BRAND IDENTITY

HOW WE CONDUCT OUR BUSINESS

Confident, Reliable and Professional

We offer our customers our knowledge, skills, people, and best services of international standards to ensure our customers' success and satisfaction.

Young & Active

We are modern and enthusiastic, with an innovative and creative mindset committed to fulfilling our customers' needs and providing our customers with great solutions.

Good Team Players

We support one another to fulfill our "Partnership for Success" culture with a common objective to deliver high value to our customers regardless of which department is involved. We work together as a team to collectively ensure our customer's success.

Customer-Led

We design our entire business around our customers' needs. Our focus is on personalized solutions and to enable our customers to experience values and services beyond their expectations.

Best Service Mind with Thai touch

We provide our customers with exemplary service akin to the legendary Thai hospitality, enabling our customers to experience our warmth and charm in the services we offer.

Modern and Progressive Venue offering a diversity of solutions

We offer our customers modern and technologically advanced facilities that provide a diversity of solutions and choices for their success.

KEY DESIGN ELEMENTS



PANTONE
2935 C

CMYK

C 100
M 68.09
Y 3.57
K 0.16

RGB

R 0
G 93
B 165



PANTONE
1505 C

CMYK

C 0
M 71.66
Y 100
K 0

RGB

R 242
G 108
B 33

Logo

1. All the letters "IMPACT MUANG THONG THANI" must be all capitalized.
2. Our new logo reflects an modern, confident and progressive organization that is reliable, caring and warm.

Colour Codes

The IMPACT logo colours are blue and orange. Blue is the dominant of the two corporate colours. In two-colour printing, blue should always be used.

The meaning of our blue and orange colours attributes our "Partnership for Success" company culture.

Blue means Trustworthy, Dependability, Responsibility, security and stability which inspire Trust.

Orange means Eagerness, Energy, Enthusiasm, Fun and Vitality.

KEY DESIGN ELEMENTS



Our Brand Mark Clear Space

Please note that spacing on every side of the "IMPACT logo" must remain clear from letters, colors, or any graphic element.

Spacing requirements are as follows:

Horizontal line x 1 (total area x 15.3)

Vertical line x 1 (total area x 5)

KEY DESIGN ELEMENTS

Minimum size of the logo

15 cm.



10 cm.



5 cm.



2.5 cm.



The minimum size of IMPACT logo should not be smaller than 2.5 cm. in width.

KEY DESIGN ELEMENTS

Logo Colour

Logotype Primary Use

Boxed logotype in White

Boxed logotype in Blue

Secondary Use

One Colour / IMPACT Blue

One Colour / Black

Reversed to white on a blue background

Reversed to white on a black background

Additional

One Colour / Gold

One Colour / Grey

Reversed to white on a gold background

Reversed to white on a gray background

Acceptable colours for IMPACT Logo are only as mentioned above

KEY DESIGN ELEMENTS

Logo Use Guidelines



Original



Reversed to white on a blue background

1. Recolouring the logo apart from original intention our is forbidden

2. Any colour adjustments apart from original intention are forbidden



3. Any proportional adjustments apart from specified are forbidden

4. Any distortion, shape adjustments, or reposition apart from specified are forbidden



KEY DESIGN ELEMENTS

Logo Background

DON'T



Don't use IMPACT logo against a graphic background

DO



Option 1

IMPACT logo may be used in corporate colours placed on specified colour background only



Option 2

IMPACT logo may be used in a light background

IMPACT'S TYPEFACES

Typography / English Media Publications; including Advertising Materials, Magazines, Journals, IMPACT's internal and external media publications, etc. should be composed with the following fonts ;

The Typeface : Frutiger LT Std

45 Light

ABCDEFGHIJKLMNOPQRSTUVWXYZ
abcdefghijklmnopqrstuvwxyz
1234567890 !%#&* <>?@

55 Roman

ABCDEFGHIJKLMNOPQRSTUVWXYZ
abcdefghijklmnopqrstuvwxyz
1234567890 !%#&* <>?@

65 Bold

ABCDEFGHIJKLMNOPQRSTUVWXYZ
abcdefghijklmnopqrstuvwxyz
1234567890 !%#&* <>?@

IMPACT'S TYPEFACES

Typography / English Media Publications; including Advertising Materials, Magazines, Journals, IMPACT's internal and external media publications, etc. should be composed with the following fonts ;

The Typeface : Frutiger LT Std

45 Light

ABCDEFGHIJKLMNOPQRSTUVWXYZ
abcdefghijklmnopqrstuvwxyz
1234567890 !%#&* <>?@

55 Roman

ABCDEFGHIJKLMNOPQRSTUVWXYZ
abcdefghijklmnopqrstuvwxyz
1234567890 !%#&* <>?@

65 Bold

ABCDEFGHIJKLMNOPQRSTUVWXYZ
abcdefghijklmnopqrstuvwxyz
1234567890 !%#&* <>?@

STANDARD COMMUNICATION

Letterhead



STANDARD COMMUNICATION

Business Card



IMPACT
MUANG THONG THANI

จินตนา พงษ์ภักดี
Jintana Phongpakdee
Director of Corporate Communications

IMPACT ARENA
IMPACT FORUM
IMPACT CHALLENGER
IMPACT EXHIBITION CENTER
NOVOTEL BANGKOK IMPACT
IBIS BANGKOK IMPACT

Tel : +66 (0) 2833-5061
Mobile : +66 (0) 92-894-9959
E-mail : jintanap@impact.co.th
Line ID : jintanajum



Managed by
IMPACT EXHIBITION MANAGEMENT CO., LTD.
10th Fl., Bangkok Land Building
47/569-576 Popular 3 Road, Banmai Sub-district,
Pakkred District, Nonthaburi 11120
GREATER BANGKOK, THAILAND.
Website : www.impact.co.th

BANGKOK LAND PUBLIC COMPANY LIMITED
UIC
uifi
IAEE



Envelope No.9



IMPACT
MUANG THONG THANI

IMPACT EXHIBITION MANAGEMENT CO., LTD.
10th Floor, Bangkok Land Building, 47/569-576 Popular 3 Road,
Banmai Sub-district, Pakkred District, Nonthaburi 11120,
GREATER BANGKOK, THAILAND
Tel : +66(0) 2833-4455 Fax : +66(0) 2833-4456
E-mail : info@impact.co.th Website : www.impact.co.th

IMPACT ARENA
IMPACT FORUM
IMPACT CHALLENGER
IMPACT EXHIBITION CENTER
NOVOTEL BANGKOK IMPACT
IBIS BANGKOK IMPACT

STANDARD COMMUNICATION

Fax

Partnership for Success



FACSIMILE

To: _____
 Company: _____
 Fax Number: _____
 From: _____
 Subject: _____
 Date: _____
 No. of Pages: _____ (Included this page)

8# External Facsimile (eng)
 IF TRANSMISSION IS INCOMPLETE, PLEASE CONTACT SENDER
 TELEPHONE: +66 2 833 XXXX FAX: +66 2 833 XXXX E-mail: xxxxxxxxxx@impact.co.th

This communication is intended only for the use of the individual or entity to which it is addressed and may contain information that is privileged and confidential. If you are not the intended recipient, or the employee or agent responsible for delivering the communication to the intended recipient, you are hereby notified that any dissemination, distribution or copying of this communication is strictly prohibited without the express consent of the sender or intended recipient. If you receive this communication in error, please notify us immediately.

Partnership for Success



FACSIMILE

To: _____
 Company: _____
 Fax Number: _____
 From: _____
 Subject: _____
 Date: _____
 No. of Pages: _____ (Included this page)

8# External Facsimile (eng)
 IF TRANSMISSION IS INCOMPLETE, PLEASE CONTACT SENDER
 TELEPHONE: +66 2 833 XXXX FAX: +66 2 833 XXXX E-mail: xxxxxxxxxx@impact.co.th

This communication is intended only for the use of the individual or entity to which it is addressed and may contain information that is privileged and confidential. If you are not the intended recipient, or the employee or agent responsible for delivering the communication to the intended recipient, you are hereby notified that any dissemination, distribution or copying of this communication is strictly prohibited without the express consent of the sender or intended recipient. If you receive this communication in error, please notify us immediately.

Memo

Partnership for Success



Department

MEMORANDUM

To:		Date:	
From:		Ref. No:	
Subject:			
CC:			
Total page:	(Including this page)		

For your comment For your information Please handle/action As requested Others

7# Internal Memo (eng)

Letter Form

Partnership for Success



<<Date>>
 <<Name>> <<Last Name>>
 <<Job Title>>
 <<Company Name>>
 <<Address>>
 <<District>>
 <<Province>> <<Postcode>>
 <<Telephone>>
 <<Facsimile>>

Subject:
 Dear.....,

Your new company stationary has been formatted as indicated by the style of this letter. The letter is to be set using the typeface "Times New Roman," 12 pt. in size with single line spacing. The left and right hand margins are inserted 30 mm.

The paper is international standard size A4. The salutation is separated by one blank line from the subject.

Paragraphs are separated by a blank line so there is no need to indent.

At the end of the letter, two blank lines are left before typing "Yours sincerely," which is separated from the name of the signatory by not less than three blank lines. Wherever possible, five blank lines should be left for the signature.

Yours sincerely,

Name
 Title

1# Formal Letter + company logo (eng)

IMPACT ARENA
 IMPACT FORUM
 IMPACT CHALLENGER
 IMPACT EXHIBITION CENTER
 NOVOTEL BANGKOK IMPACT

IMPACT EXHIBITION MANAGEMENT CO., LTD.
 10th Floor, Bangkok Land Building, 47/56-57 A Popular 3 Road,
 Bannnai Sub-district, Pakkred District, Nonthaburi 11120,
 ORCHESTER BANGKOK, THAILAND
 Tel : +66(0) 2833-4456 Fax : +66(0) 2833-4456
 E-mail : info@impact.co.th Website : www.impact.co.th

STANDARD COMMUNICATION

E-mail Signature

The whole company email signature must be in the same format to imply the unity of the corporations' working standard.

The font used for email signature is

Arial / Regular
Size = 10 Points
and in black color only.

You can request E-mail footer picture via :
communications@impact.co.th
Tel : 0 -2833-5069

Format Example

JINTANA PHONGPAKDEE
Corporate Communications Director

Corporate Communications Department
IMPACT EXHIBITION MANAGEMENT CO., LTD.

10th Fl., Bangkok Land Building
47/569-576 Popular 3 Road, Banmai Sub-district,
Pakkred District, Nonthaburi 11120
GREATER BANGKOK, THAILAND.

Tel : +66 (0)2833-5061
Fax : +66 (0)2833-5060
Mobile : 089-xxx-xxxx
E-mail : jintanap@impact.co.th
Website : www.impact.co.th



STANDARD COMMUNICATION

PowerPoint® Template

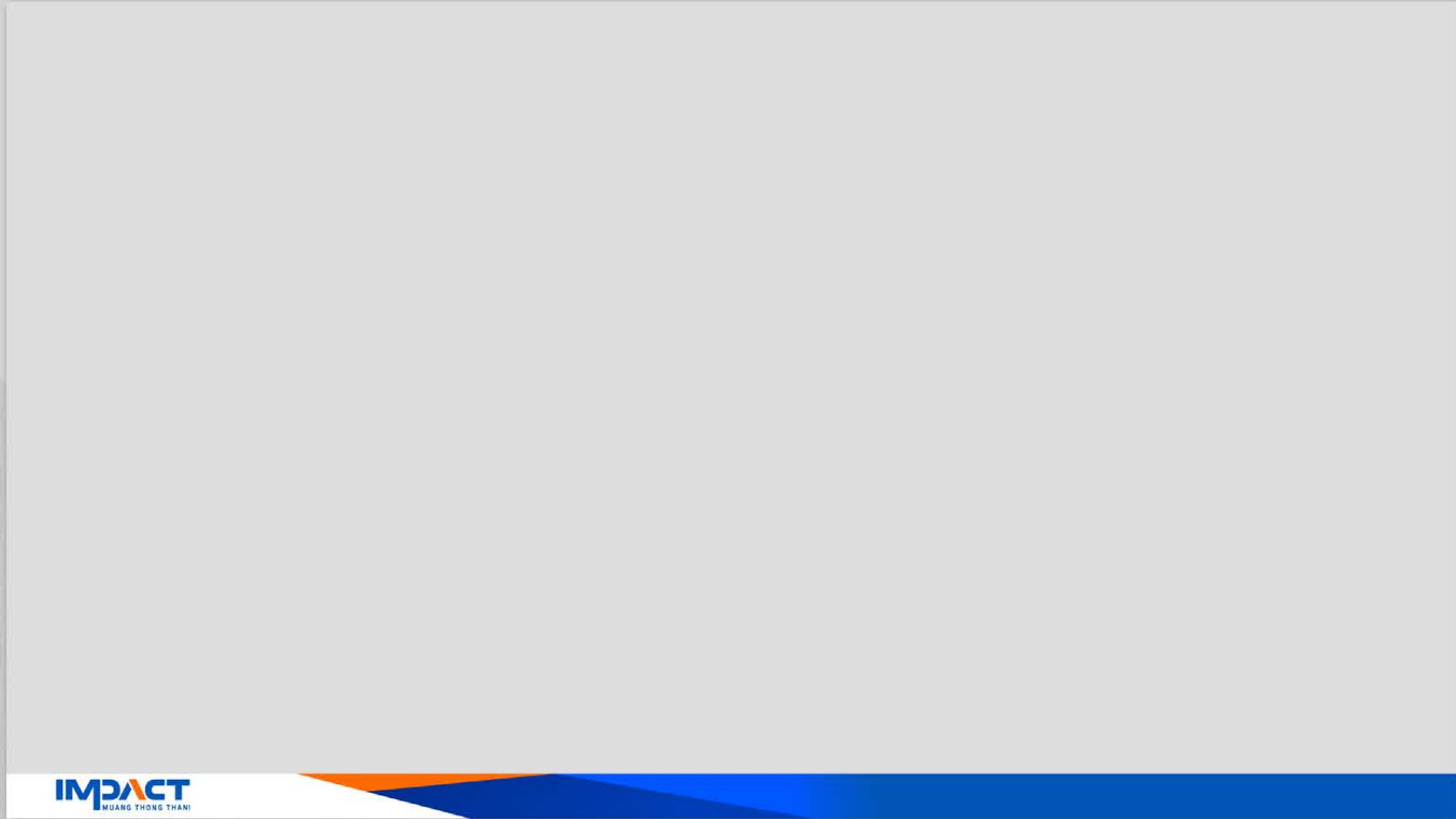

You can download IMPACT's PowerPoint template at http://www.impact.co.th/download/IMPACT_PPW2025A.pptx

OUR RESTAURANT CHAINS

Introduction

The objective of determining colour schemes for each food and beverage outlet is to create IMPACT restaurants' brand awareness among the public.



OUR RESTAURANT CHAINS

Restaurants in the area

CHINESE RESTAURANTS

Hong Kong Fisherman

Lobby Hall 12, IMPACT Exhibition Center

Tel : +66 (0) 2833-5434-5

Opening Hours : 11:00-22:00 hrs.

Hong Kong Café

Food Atrium, IMPACT Challenger 3

Tel : +66 (0) 2833-4044

Opening Hours : 11:00-21:00 hrs.

Hong Kong Suki

2nd Floor, THE PORTAL Lifestyle Complex

Tel : +66 (0) 2040 8176

Opening hours: 11:00-20:00 hrs.

*Business hours vary depending on the events taking place



Hong Kong
Fisherman

Hong Kong Fisherman
Lobby Hall 12, IMPACT Exhibition Center



Hong Kong Café
Food Atrium / IMPACT Challenger 3



Hong Kong SUKI
2nd Floor, THE PORTAL



OUR RESTAURANT CHAINS

Restaurants in the area

JAPANESE RESTAURANTS

Tsubohachi

The Portal Lifestyle Complex

Business hours vary depending on the events taking place: 11:00-20:00 hrs. (Last order 19:30 hrs.)

☎ 02 033 1864 🌐 www.tsubohachi-tha.com

Nippon Yokocho

Food Atrium / IMPACT CHALLENGER 3

Monday - Thursday : 11.00 - 20.00 hrs.

Friday - Saturday : 11.00 - 24.00 hrs.

Exhibition days : 11.00 - 24.00 hrs.

☎ 02 580 1664 🌐 www.facebook.com/Nipponyokochoth

Taisho-Tei

Food Atrium / IMPACT CHALLENGER 3

Open daily from 11:00-20:00 hrs.

☎ 02 833 4284 🌐 www.facebook.com/TaishoteiRamen



OUR RESTAURANT CHAINS

Restaurants in the area
International Food

FLANN O'BRIEN'S IRISH PUB

Flann O'Brien's Irish Pub @IMPACT

Food Atrium, IMPACT Challenger 3

Tel : 02-833-4288

Opening Hours: 16:00-24:00 hrs.

*Business hours vary depending on the events taking place



ORIGINAL



Full CMYK

TWO COLOR



ONE COLOR



OUR RESTAURANT CHAINS

Restaurants in the area
International Food

Terrazza Restaurant & Bar

Hall 5, IMPACT EXHIBITION CENTER

Tel : 02-833-5432-33

ORIGINAL / TWO COLOR (Spot)



	C 50	M 70
	Y 60	K 80
	C 25	M 38
	Y 97	K 3



OUR RESTAURANT CHAINS

Restaurants in the area
International Food

Retro Bar & Café

1st Fl., THE PORTAL Lifestyle Complex
Tel : 02 006 2054

Opening Hours: 16:00-24:00 hrs.

*Business hours vary depending on the events taking place



Two-Tone



Single Colour



PANTONE 1785 C	PANTONE 874 C
PANTONE 7455 C	

OUR RESTAURANT CHAINS

Restaurants in the area
THAI Food

THONGLOR Authentic Thai Cuisine - Halal

Lobby 3, IMPACT CHALLENGER

Tel : 02-833-4038



Original



Two Colours



OUR RESTAURANT CHAINS

Restaurants in the area
THAI Food

ISAN at ARENA

2nd Floor, THE PORTAL Lifestyle Complex
Tel : 02 033 1863

Opening Hours: 11:00-20:00 hrs.

*Business hours vary depending on the events taking place

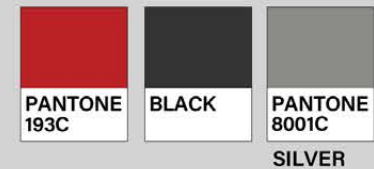

OUR RESTAURANT CHAINS

Restaurants in the area

Coffee & Beverage / Cafeteria

EASE CAFÉ

- Lobby IMPACT CHALLENGER 2

Tel : 02-833-4282-3

- Lobby IMPACT FORUM / Hall 4

Open on Exhibition days

(The time is according to the exhibition at IMPACT Challenger and IMPACT Forum)



ORIGINAL / TWO COLOR (Spot)

อีส คาเฟ่
EASE
CAFÉ



อีส คาเฟ่
EASE cafē





OUR RESTAURANT CHAINS



Restaurants in the area

Coffee & Beverage / Cafeteria



 IMPACT Challenger, LOBBY Hall 3

 11:00-20:00 hrs.
Note: Open only on selected event days

  TheCoffeeAcademicsTH

THE COFFEE ACADEMİCS



THE COFFEE ACADEMİCS

OUR RESTAURANT CHAINS

Restaurants in the area

Coffee & Beverage / Cafeteria



Garage & Roaster

6 Zero Garage & Roaster

- Ground floor, Indoor Parking 3
- 08:00-18:00 hrs.
- 6zero.coffee
- 6zero_garage_and_roaster
- 081 234 0858

6 Zero Garage & Roaster has vividly become a meeting destination for car enthusiasts as well as coffee lovers who just enjoy sipping coffee and eat, sleep, and breath cars. Growing up falling in love with cars, the store owner intends to create a space where classic and rare automobiles can be admired up close. Combining this love for cars with a deep appreciation for coffee, the idea for 6 Zero Garage & Roaster came to life. Here, it's more than just a showroom. It's a café that serves freshly roasted, high-quality coffee, carefully selected and roasted in-house to deliver a rich, aromatic, and perfectly balanced cup.



OUR RESTAURANT CHAINS

Restaurants in the area
FOOD COURT

THAI THAI Food Court

Atrium 2 - Food Atrium

Opening Hours: Exhibition Days from 11 a.m. to 8 p.m.

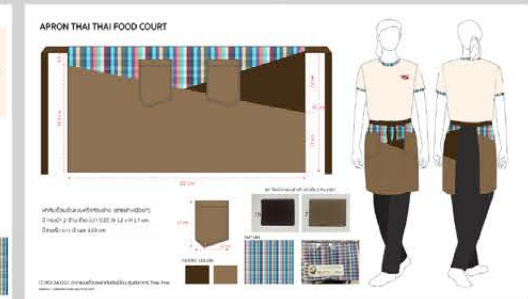

OUR RESTAURANT CHAINS

Restaurants in the area
FOOD COURT

SKY KITCHEN

IMPACT CHALLENGER 3

Opening Hours: Exhibition Days from 11 a.m. to 8 p.m.





Font & Type

Headline — Baskerville Old Face

Subheader Secondary — Optima

Highlight — *Mighty River*

Body Copy (Eng/Thai) — Prompt

AaBbCcDdZz
NnOoPpQqRrSsTtUuVvWwXx
OPQRSTUVWXYZ
1 2 3 4 5 6 7 8 9 0
AaBbCcDdEeFfGgJjKkLlMm

REVERSE



COLOR PALETTE



#141924 #2D3A4C #B2612B #BB8937 #F3E2B1

Polo Cashier Uniform Design สีน้าเงินปีกด้านหน้า + กางเกง



เสื้อ Polo Uniform สีน้ำเงินปีกด้านหน้าและด้านหลัง มีกระดุมที่คอ 1 จุด ขนาด 4.5x3.4 cm.

7099 U (หน้า)
297 U (หลัง)

เสื้อ polo สีเหลือง Uniform พนักงานบริการ



เสื้อ polo สีเหลือง Uniform พนักงานบริการ ขนาด 4.5 cm.

7099 U (หน้า)
600 U (หลัง)





OUR RESTAURANT CHAINS

Restaurants in the area
FOOD COURT



FOOD ARENA

3rd Floor, The Portal Lifestyle Complex

10:00-20:00 hrs. (Extend to 9 PM on concert day at IMPACT Arena)

www.facebook.com/foodarenatheportal



OUR RESTAURANT CHAINS

Restaurants in the city

"Hey Yin" Chinese Restaurant



Celebrating Culinary Abundance

HEI YIN is a dining concept inspired by an ancient Cantonese legend, with an intention to celebrate of the culinary abundance and expertise renowned to Cantonese cuisine.

📍 3rd Floor, Gaysorn Village, 999 Phloen Chit Rd, Lumpini, Pathum Wan District, Bangkok, Thailand, Bangkok

🕒 11:00-15:00 hrs. and 18:00-22:00 hrs.

📱 HeiYinBangkok

🌐 <https://www.heiyinbangkok.com>

☎ 080 964 5423



OUR RESTAURANT CHAINS

Restaurants in the city

XIAN YUAN
Chinese Restaurant

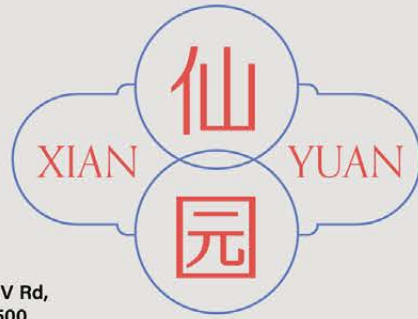

 5th Floor, Dusit Central Park, 946 Rama IV Rd, Si Lom, Bang Rak, Bangkok, Thailand, 10500

 Always open

  XianYuanBangkok

 www.xianyuanbangkok.com

 084 237 1636

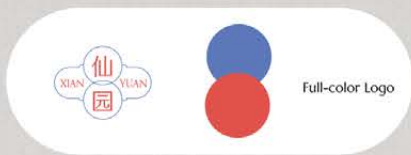

OUR RESTAURANT CHAINS

Restaurants in the city

THE COFFEE ACADEMİCS



THE COFFEE ACADEMİCS

STANDARD COLOR

Primary Color



Pantone: 1255C
4C: 30C 45M 100Y 8K



Black



White

PANTONE 1255C



STANDARD FONT

Primary font

DIN CONDENSED BOLD
ABCDEFGHIJKLMNOPQRSTUVWXYZ
1234567890!@#\$%^&*()

Supplementary font

DINPro Bold
ABCDEFGHIJKLMNOPQRSTUVWXYZ
abcdefghijklmnopqrstuvwxyz
1234567890!@#\$%^&*()

DINPro Medium
ABCDEFGHIJKLMNOPQRSTUVWXYZ
abcdefghijklmnopqrstuvwxyz
1234567890!@#\$%^&*()

DINPro Regular
ABCDEFGHIJKLMNOPQRSTUVWXYZ
abcdefghijklmnopqrstuvwxyz
1234567890!@#\$%^&*()

C29 M45 Y100 K6



Velaa Sindhorn Village
Shop B114, Velaa Sindhorn Village

☎ 07:00-20:00 hrs.
☎ 02-164-2500
🌐 <https://www.the-coffeeacademicsth.com>
📍 TheCoffeeAcademicsTH

Gaysorn Village
G Fl, Gaysorn Tower, Gaysorn Village

☎ 08:00-20:00 hrs.
☎ 02-253-6399
🌐 <https://www.the-coffeeacademicsth.com>
📍 TheCoffeeAcademicsTH

Central World
2nd Floor, Eden Zone

☎ 10:00-22:00 hrs.
☎ 02-118-6169
🌐 <https://www.the-coffeeacademicsth.com>
📍 TheCoffeeAcademicsTH

KINGSQUARE Community Mall
1st Floor, KINGSQUARE Community Mall

☎ 07:00-21:00 hrs.
☎ 063-895-1378
🌐 <https://www.the-coffeeacademicsth.com>
📍 TheCoffeeAcademicsTH



SOCIAL MEDIA

www.the-coffeeacademicsth.com TheCoffeeAcademicsTH

OUR RESTAURANT CHAINS

Restaurants in the city



Beehive Lifestyle Mall
 10:00-22:00 hrs.
 Tsubohachi Thailand
 @tsubohachith
<https://www.tsubohachi-tha.com>
 02-000-2180

The Promenade
 3rd Floor
 10:00-22:00 hrs.
 Tsubohachi Thailand
 @tsubohachith
<https://www.tsubohachi-tha.com>
 02-947-6265

Robinson Lifestyle Ratchaphruek
 1st Floor
 Mon-Thu : 11:00-22:00 hrs.
 Fri-Sat-Sun : 10:00-22:00 hrs.
 Tsubohachi Thailand
 @tsubohachith
<https://www.tsubohachi-tha.com>
 02-126-0049

Zpell at Future Park
 2nd Floor, West wing
 Mon-Thu : 10:30-21:30 hrs.
 Fri : 10:30-22:00 hrs.
 Sat-Sun / Public Holiday : 10:00-22:00 hrs.
 Tsubohachi Thailand
 Tsubohachi Thailand
 @tsubohachith
<https://www.tsubohachi-tha.com>
 02-150-9055

Cosmo Bazaar
 1st Floor
 10:00-21:00 hrs.
 Tsubohachi Thailand
 Tsubohachi Thailand
 @tsubohachith
<https://www.tsubohachi-tha.com>
 02-288-0098

Central Westgate
 G Floor
 10:00-22:00 hrs.
 Tsubohachi Thailand
 Tsubohachi Thailand
 @tsubohachith
<https://www.tsubohachi-tha.com>
 02-000-8223



IMPACT CULINOVA



IMPACT CATERING

We are committed to creating the perfect gastronomic experience, whatever style of dining and catering theme you require. No effort will be spared to make your event and occasion to remember. With a comprehensive range of flexible, external catering offerings, we will work with you to customize our food and service offering to be in sync with the total event experience. Our team is experienced in all aspects of planning - in addition to a dining experience that lingers beyond the palate, we offer an impeccable experience to cater to your every need.



Background White

Background Brown





Background Black



<p>Gold</p> <p>Pantone 7502 C HEX - D9 7E 34 CMYK - 14 28 02 12 HEX - 8E9990</p>	<p>Dark Brown</p> <p>Pantone 7596 C HEX - 40 37 23 CMYK - 42 70 79 69 HEX - 3C2817</p>	<p>Black</p> <p>Pantone 419 C HEX - 25 25 25 CMYK - 0 0 0 90 HEX - 1A1A1A</p>	<p>White</p> <p>Pantone White HEX - 255 255 255 CMYK - 0 0 0 0 HEX - FFFFFF</p>
--	--	---	---

 www.impact-catering.com

  [impactcatering](https://www.tiktok.com/@impactcatering)

 [impactcateringth](https://www.instagram.com/impactcateringth)

 [@impactcatering](https://www.linkedin.com/company/impactcatering)

 080 833 5252



THE LAKE CLUB

The Lake Club

Everyday Club for All

The Lake Club is designed to function as:

- A third place (between home and work)
- A multi-speed environment (day → night, calm → social)
- A collective lifestyle platform

Operating Hours:

8:00 AM – 10:00 PM

(Guests are welcome to enjoy the venue until midnight)

☎ **063-837-2653**

📘 **The Lake Club**

© **thelakeclub.th**



SIGNAGE

Introduction

IMPACT signposts are separated these categories :

1. DIRECTIONAL SIGNPOST

- 1.1 Indoor direction signpost
 - 1.1.1 Directory Stand
 - 1.1.2 Pole Stand
- 1.2 Outdoor direction signpost

2. ADVERTISING BOARD

- 2.1 Lollipop
- 2.2 Billboard Oposite Hong Kong Fisherman 10 x 6 m.
- 2.3 Billboard Express way 20 x 10 m.
- 2.4 IMPACT Exhibition Hall 9 / Banner (Outdoor)
- 2.5 AMBER wall / Banner (Outdoor)

3. LED Wall and Digital TV

- 3.1 LED wall at IMPACT Challenger 2 lobby
- 3.2 LED wall at IMPACT Challenger 1 & 3
- 3.3 LED wall at IMPACT Forum (Extrance 1/ Outside)
- 3.4 LED wall at IMPACT Forum- Link bridge (Novotel)
- 3.5 Digital TV at IMPACT Challenger
- 3.6 Digital TV at IMPACT Forum
- 3.7 Digital TV at IMPACT Exhibition Center
- 3.8 LED - Link bridge - The Portal to IMPACT Challenger
- 3.9 LED Cube
- 4.0 LED Royal Jubilee (Outdoor/IMPACT Challenger1)
- 4.1 LED The Portal (Totem)
- 4.1 SKY ENTRANCE - LED (Outdoor)
- 4.2 Sky Entrance - Lobby LED (Indoor)

BANGKOK LAND signposts are separated these categories :

1. ADVERTISING BOARD

- 1.1 Under Link Bridge / Column / Banner
- 1.2 P1 - Long Board
- 1.3 P1 - Pylon Billboard w 20 x h 10 m. (1 side)
- 1.4 Tiwanon - Pylon Billboard w 20 x h 10 m. (2 Sides)

2. LED

- 2.1 P1 - Pylon LED

SIGNAGE

IMPACT CHALLENGER > Ground Floor

1. DIRECTIONAL SIGNPOST

1.1 Indoor direction signpost

1.1.1 Directory Stand

1.1.2 Pole Stand

IMPACT CHALLENGER

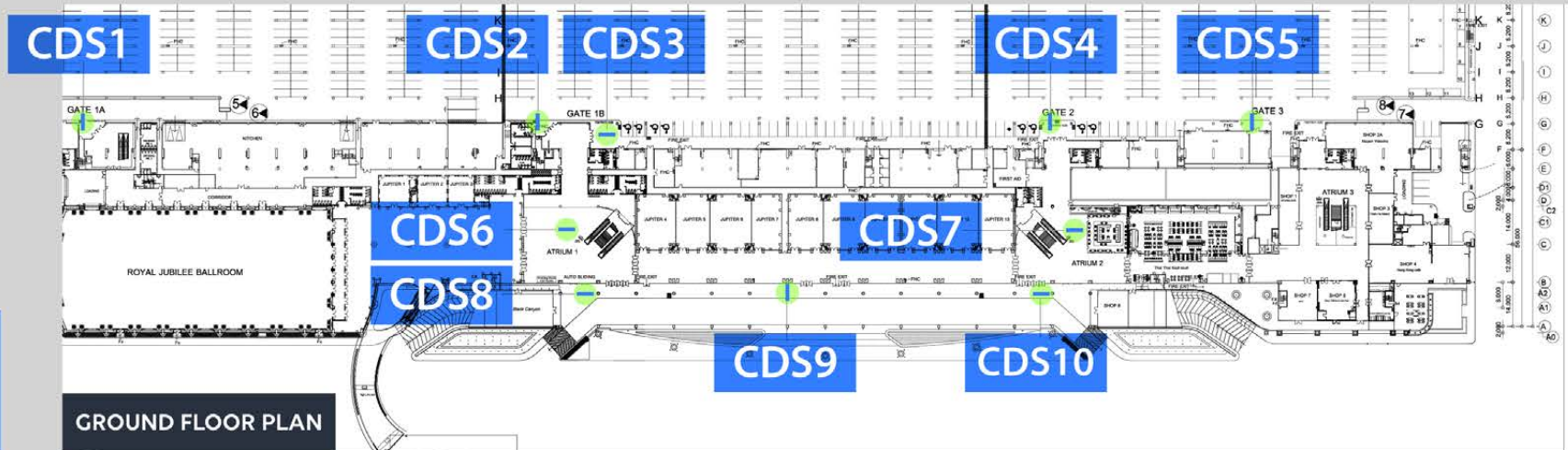

IMPACT CHALLENGER
Directional Stand

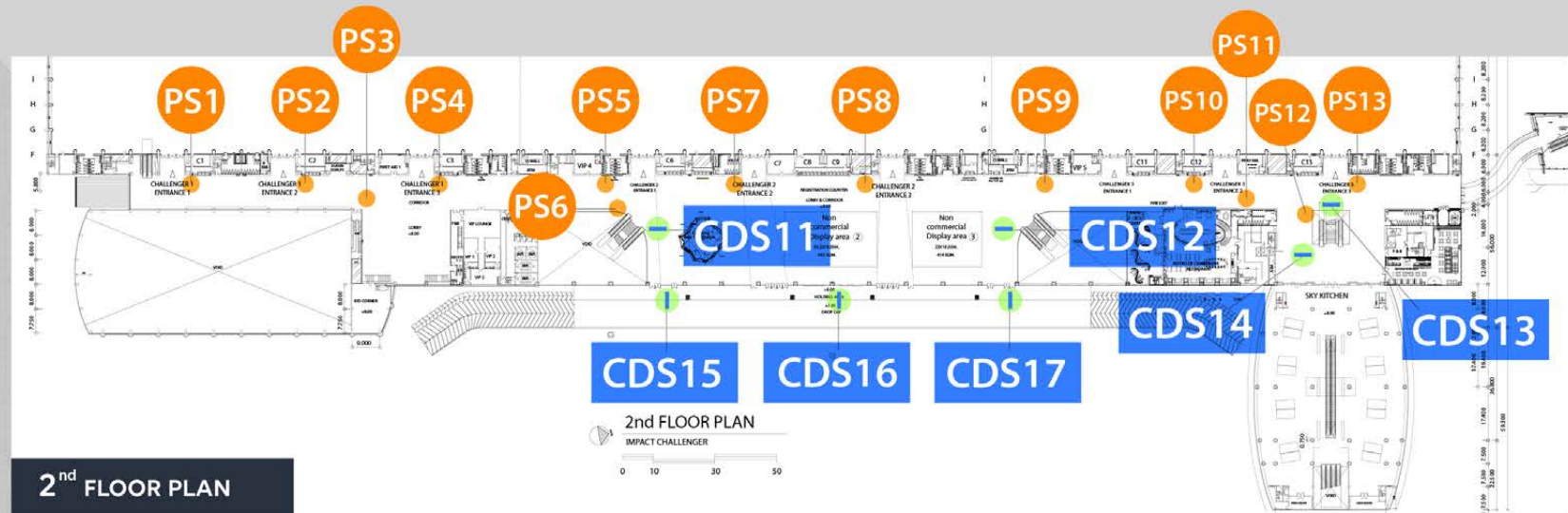

Pole Stand

SIGNAGE

IMPACT CHALLENGER



1. DIRECTIONAL SIGNPOST

1.1 Indoor direction signpost

1.1.1 Directory Stand

1.1.2 Pole Stand



Directory Stand

Directory Stand

Code : DS
Location : Challenger
Type : Directional
Lightbox
Quantity : 21 units



Pole Stand

Pole Stand

Code : PO
Location : Challenger
Type : Directional
Lightbox
Quantity : 14 units

SIGNAGE

LED Wall and Digital TV

Digital TV at IMPACT Exhibition Center

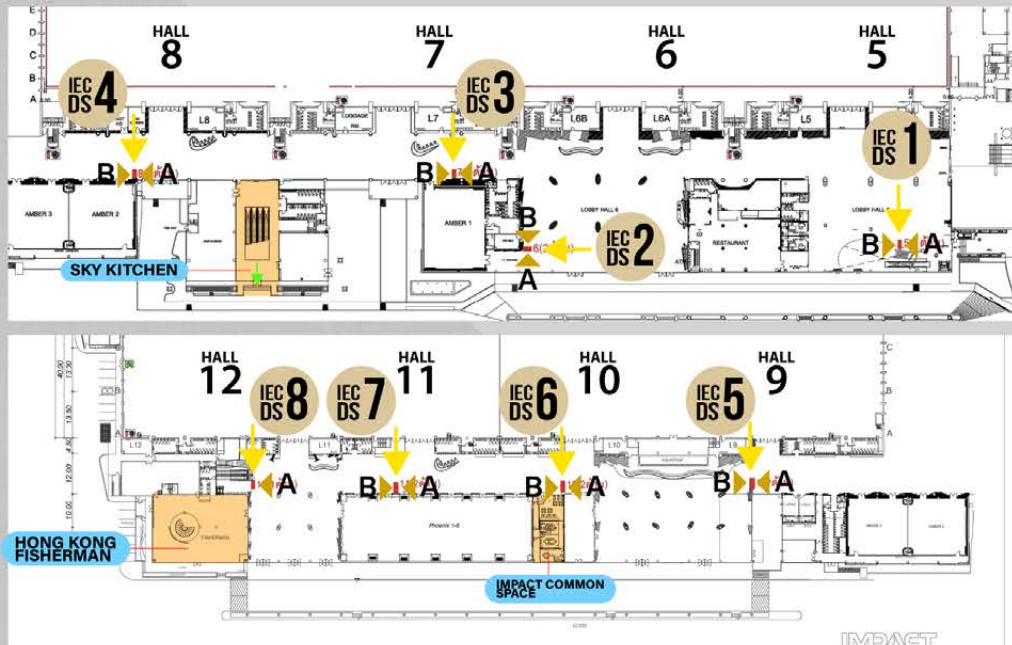
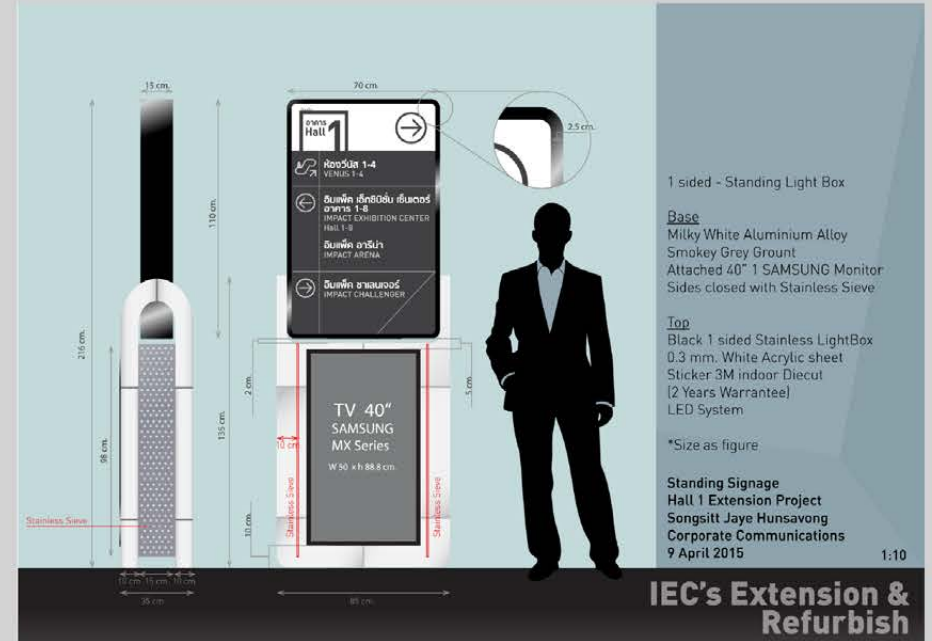

SIGNAGE

LED Wall and Digital TV

Digital TV at IMPACT Forum

 IMPACT FORUM DIRECTIONAL
 TV STAND SIGNAGE ZONE B
IFDB....
4 Units
 (1st Floor = 2 Units
 2nd Floor = 2 Units)

 IMPACT FORUM DIRECTIONAL
 TV STAND SIGNAGE ZONE A
IFDA....
5 Units
 (1st Floor = 2 Units
 2nd Floor = 3 Units)

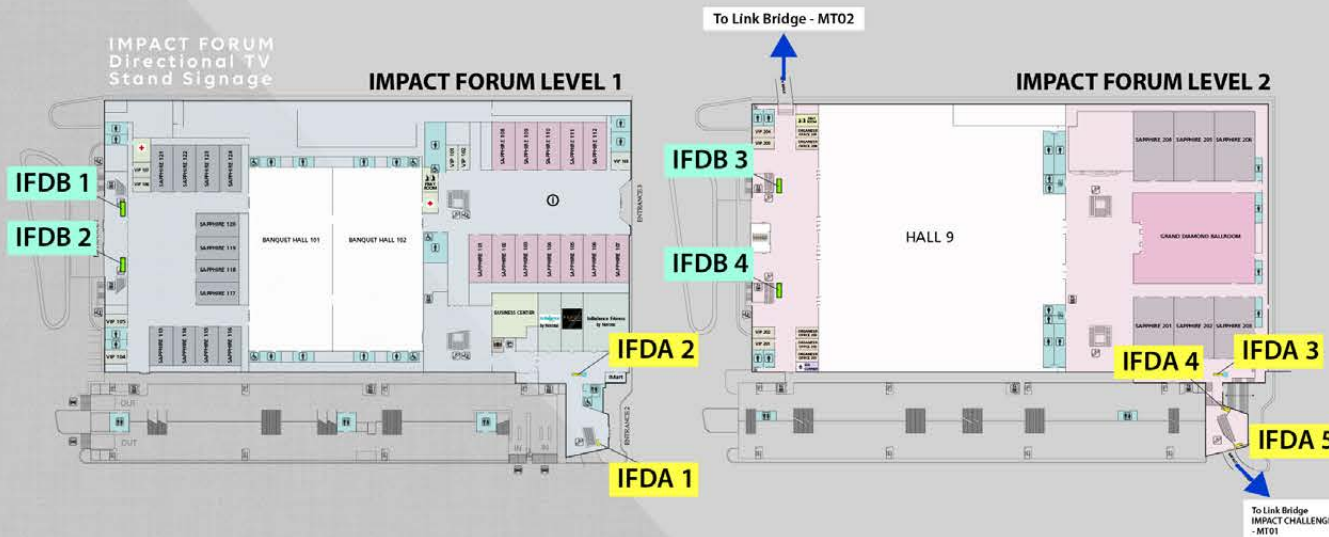
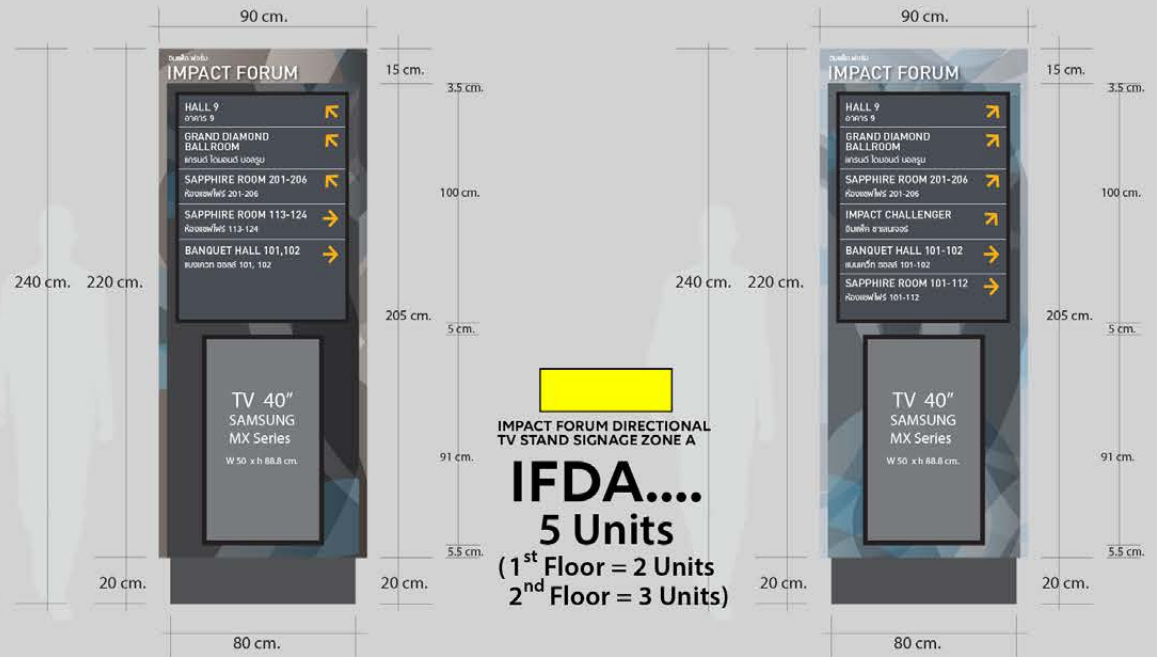

SIGNAGE

LED Wall and Digital TV

LED wall at IMPACT
Challenger 2 lobby

Size : w 17.28 x h 4.32 m.
Media : DVD format , AVI , MPEG , WMV



Sponsor
w 576 x h432 pixels

Exhibitor events
w 1152 x h432 pixels

SIGNAGE

3. LED Wall and Digital TV

3.2 LED wall at IMPACT Challenger 1 & 3

Size : w 576 x h 432 pixels

Media : DVD format , AVI , MPEG , WMV

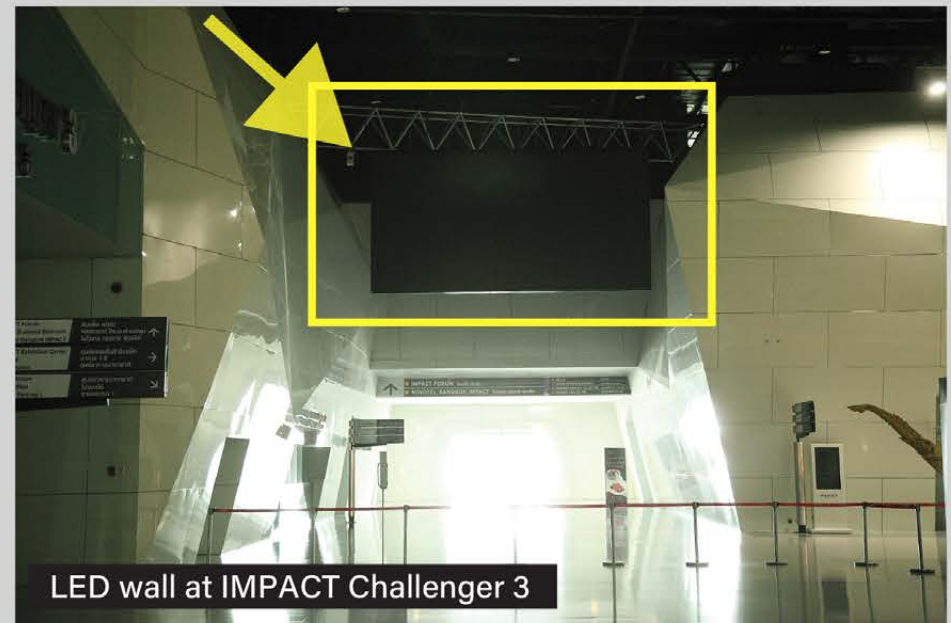
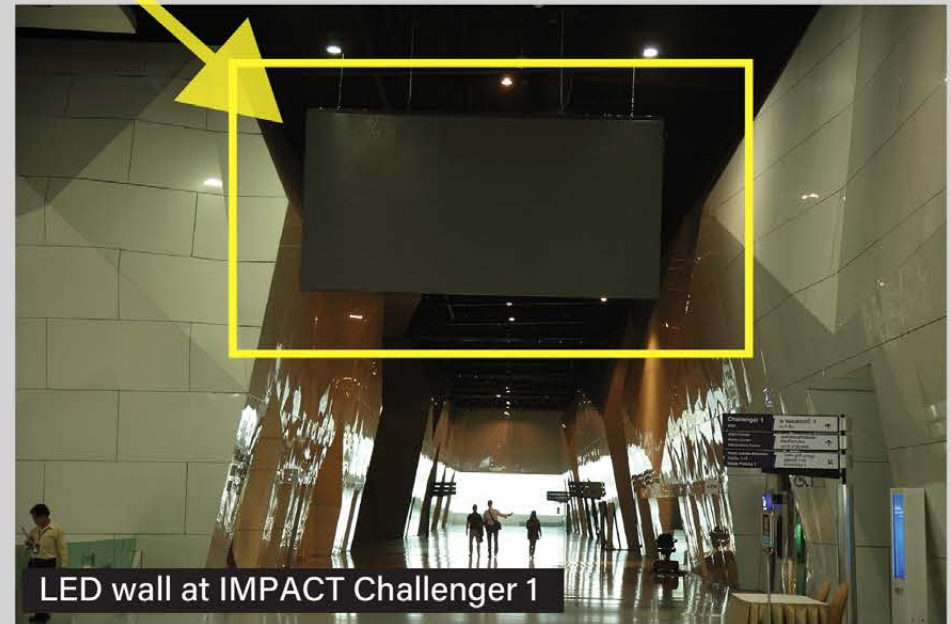

SIGNAGE

LED Wall and Digital TV

Digital TV at
IMPACT Challenger

Resolution : w 1980 x h 1080 Pxs.

CDS IMPACT CHALLENGER
Directional Stand



PS Pole Stand



Digital
Signage

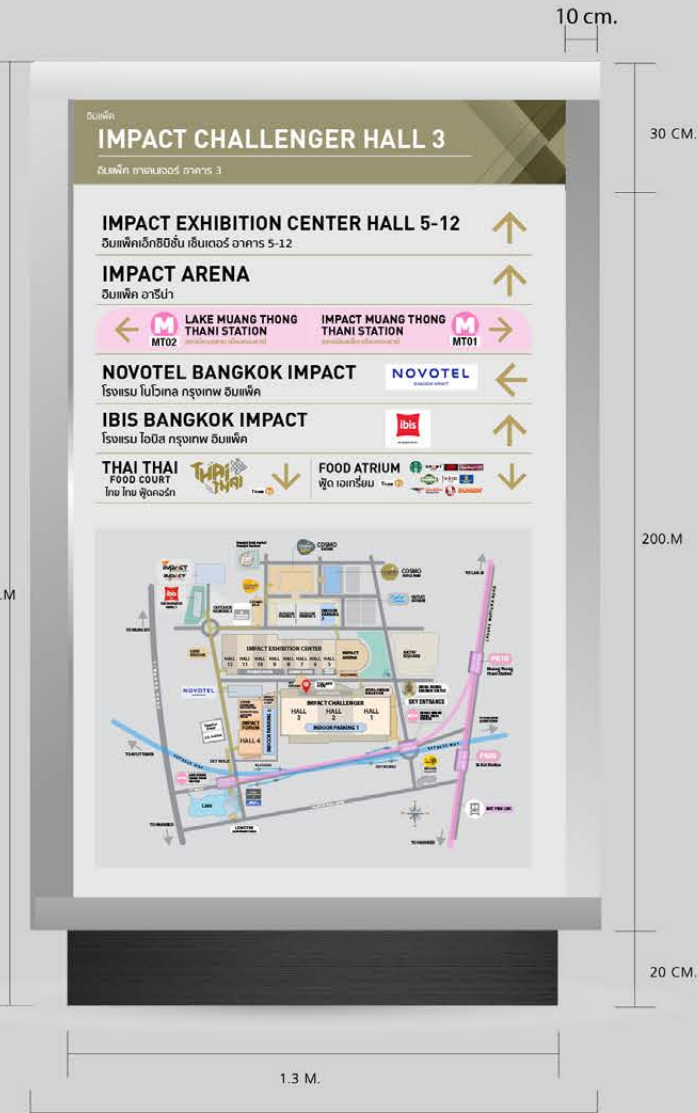
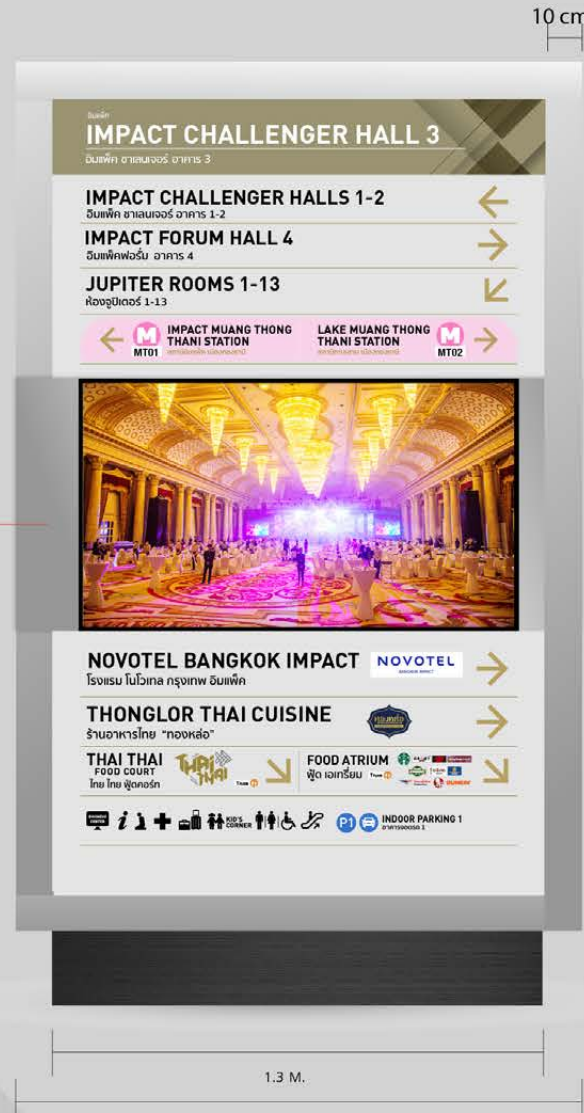

SIGNAGE

LED Wall and Digital TV

Digital TV at IMPACT Exhibition Center

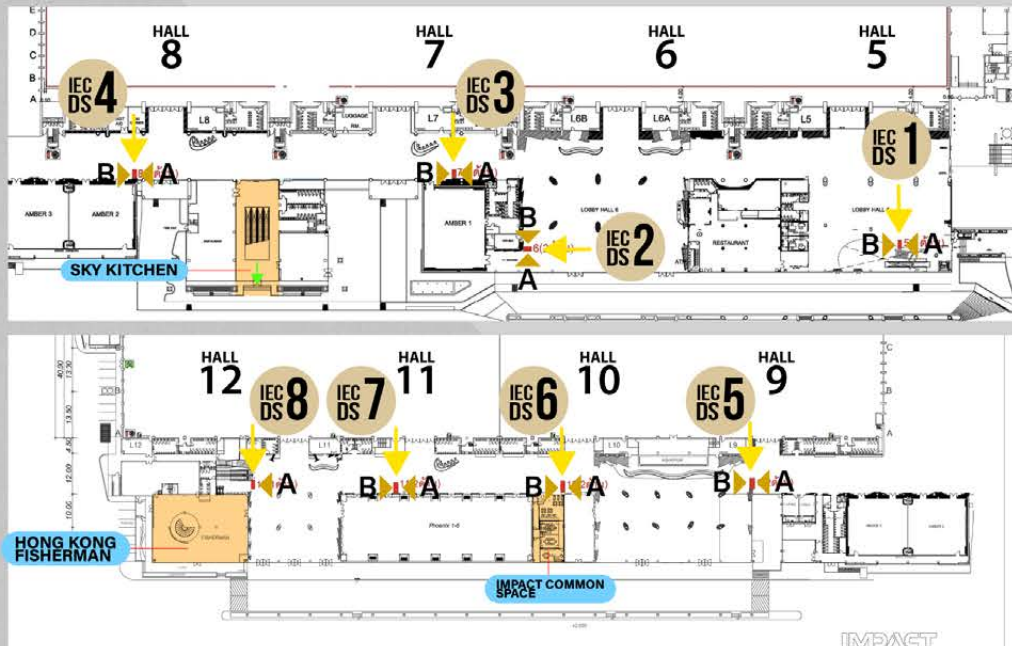
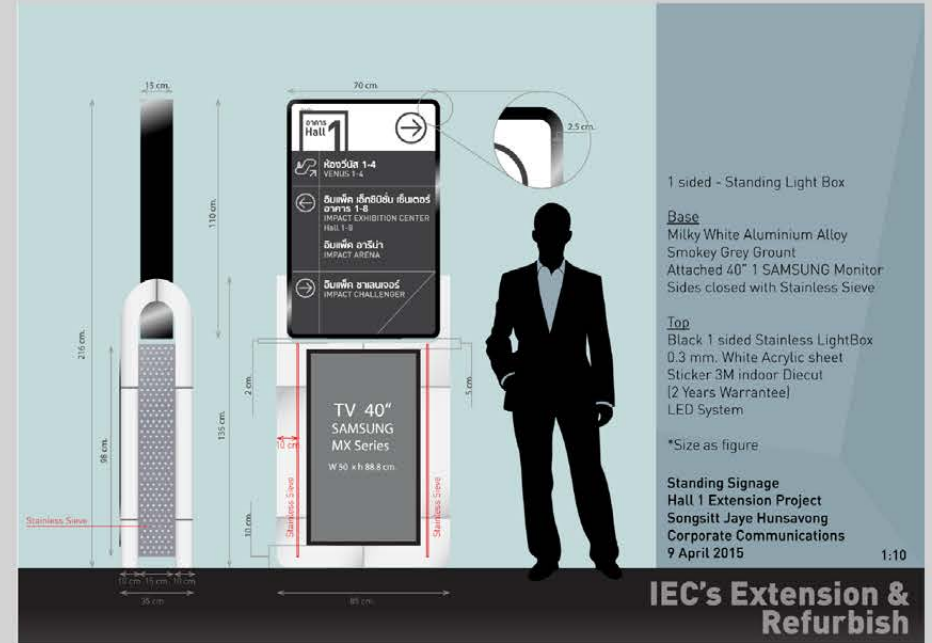

SIGNAGE

LED Wall and Digital TV

Digital TV at IMPACT Forum

 IMPACT FORUM DIRECTIONAL
 TV STAND SIGNAGE ZONE B
IFDB....
4 Units
 (1st Floor = 2 Units
 2nd Floor = 2 Units)

 IMPACT FORUM DIRECTIONAL
 TV STAND SIGNAGE ZONE A
IFDA....
5 Units
 (1st Floor = 2 Units
 2nd Floor = 3 Units)

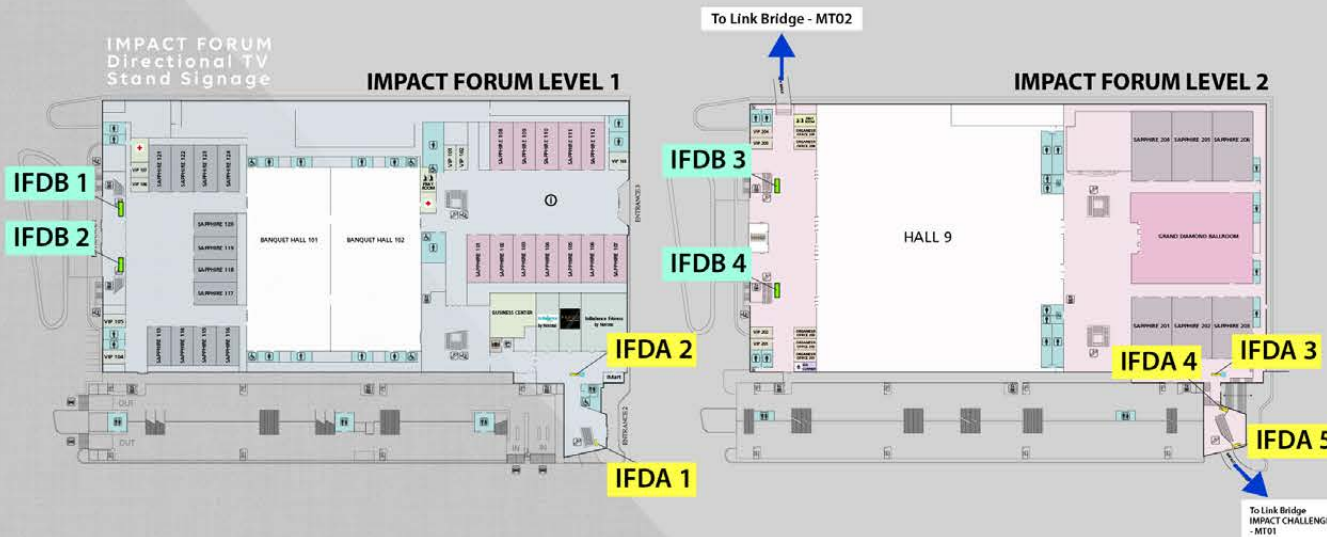
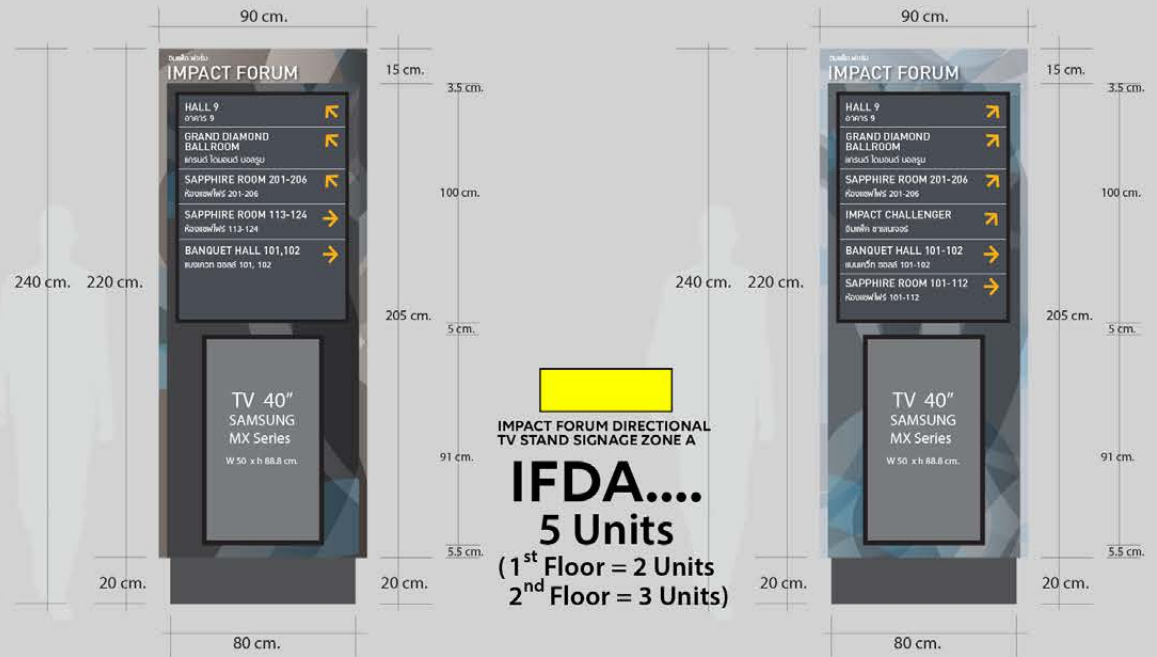

SIGNAGE

LED Wall and Digital TV

LED wall at IMPACT Forum-
Link bridge (Novotel)



Size : w 1600 x h 1500 pixels

Media : DVD format , AVI , MPEG , WMV

SIGNAGE

ADVERTISING BOARD

- | | | | |
|-----|--|-----------------------|--|
| 2.1 | Lollipop | MA, MB, MC, MD | ■ |
| | Quantity : | 48 boards | |
| | Code : | MA - MD | |
| | Size : | w 150 x h 220 cm. | |
| | MA 01 - | MA 15 | |
| | MB 01 - | MB 11 | |
| | MC 01 - | MC 07 | |
| | MD 01 - | MD 15 | |
| | Size : | w 150 x h 220 cm. | |
| 2.2 | Billboard | ME 1, ME 2 | ■ |
| | Quantity : | 2 boards | |
| | Code : | ME | |
| | Size : | w 10 x h 6 metres | |
| 2.3 | Billboard Expressway | | ■ |
| | Quantity : | 3 boards x 2 sides | |
| | Code : | MF | |
| | Size : | w 20 x h 10 metres | |
| 2.4 | IMPACT Exhibition Hall 9/ Banner (Outdoor) | | ■ |
| | Quantity : | 1 board | |
| | Code : | MG | |
| | Size : | w 10.6 x h 8.9 metres | |
| 2.5 | AMBER Wall / Banner (Outdoor) | | ■ |
| | Quantity : | 2 boards | |
| | Code : | MH | |
| | Size : | w 10.2 x h 4 metres | |

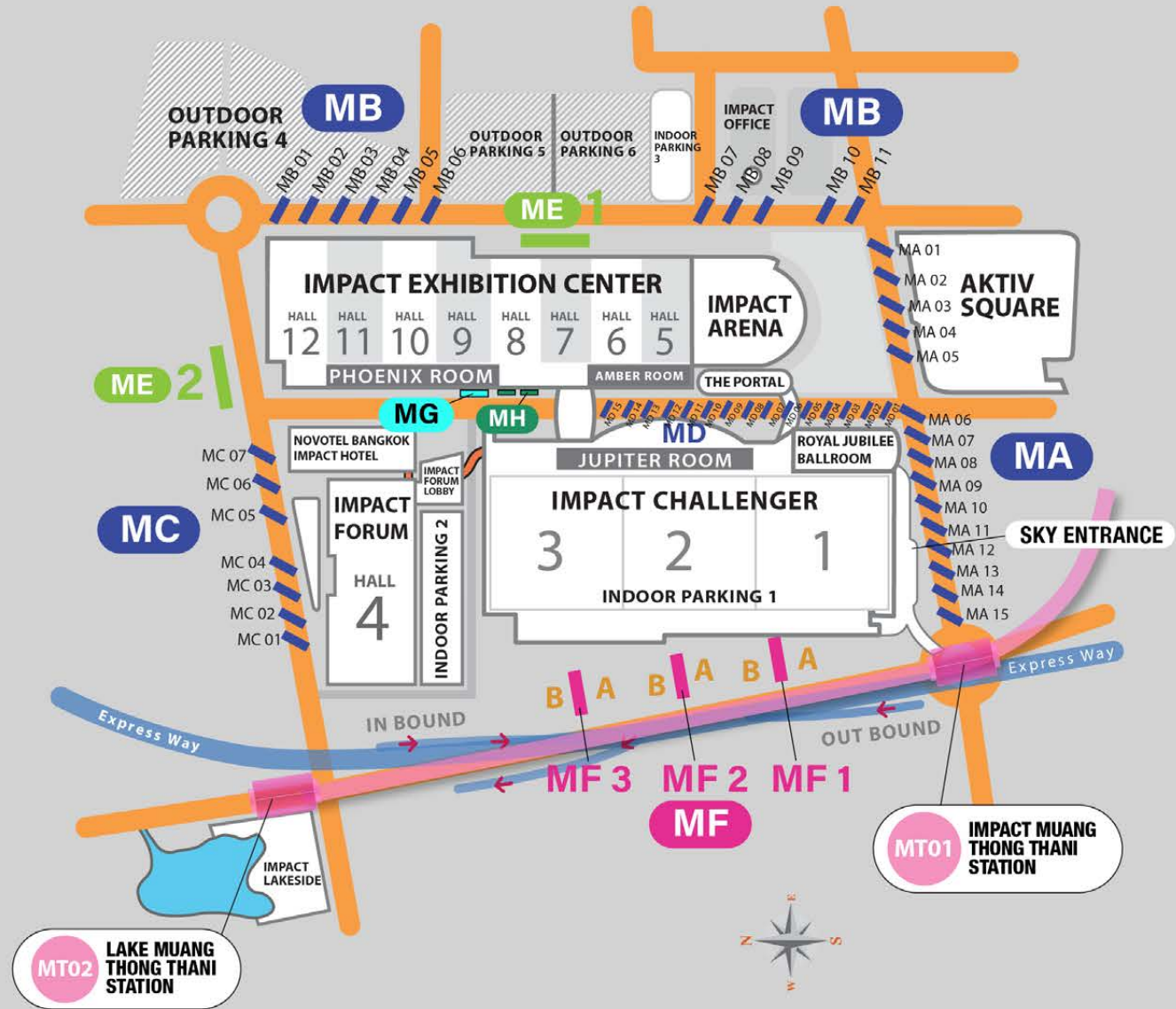

SIGNAGE

ADVERTISING BOARD

Lollipop MA, MB, MC, MD
Quantity : 48 boards
Size : w 150 x h 220 cm.

Code : MA - MD
MA 01 - MA 15
MB 01 - MB 11
MC 01 - MC 07
MD 01 - MD 15

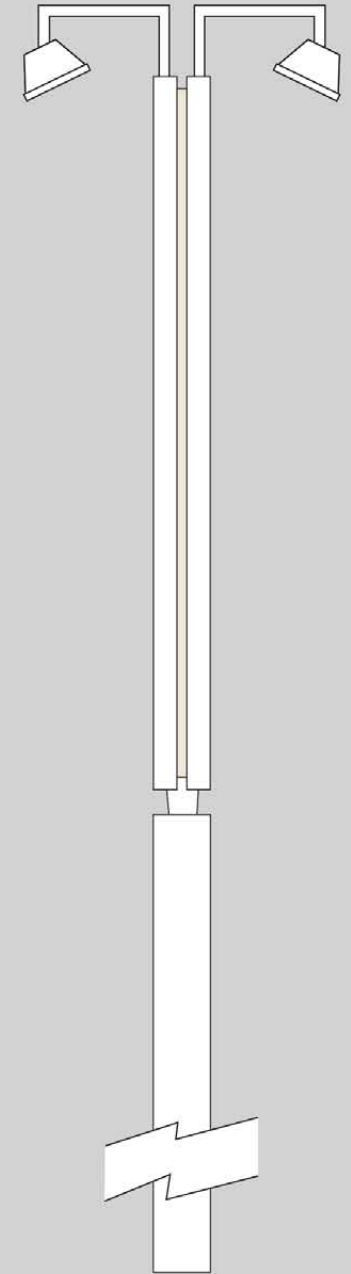
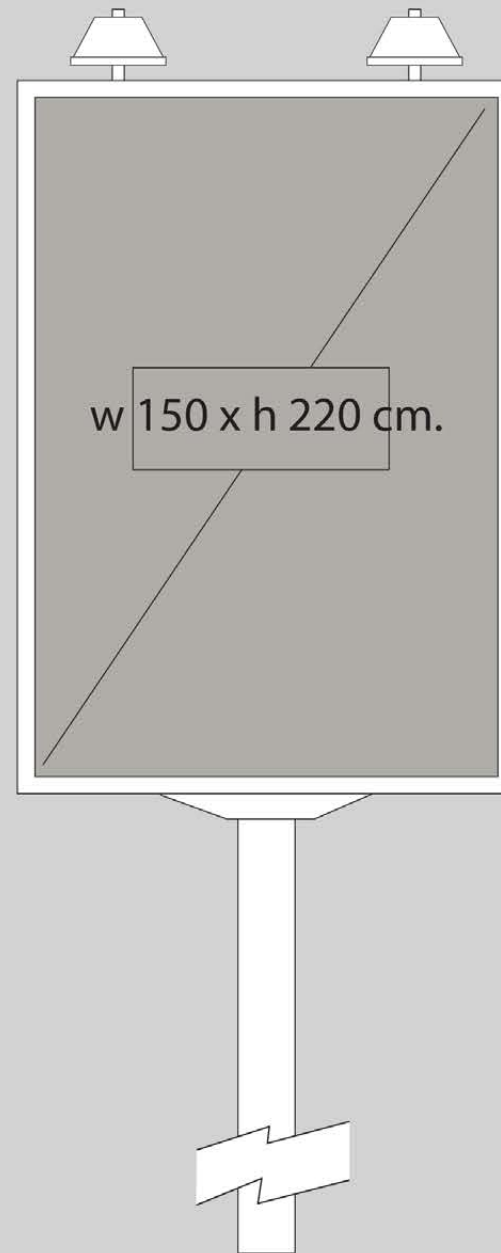

SIGNAGE

ADVERTISING BOARD

Billboard ME 1, ME 2

Quantity : 2 boards

Code : ME

Size : w 10 x h 6 metres

OPPOSITE OF IMPACT EXHIBITION CENTER HALL 12

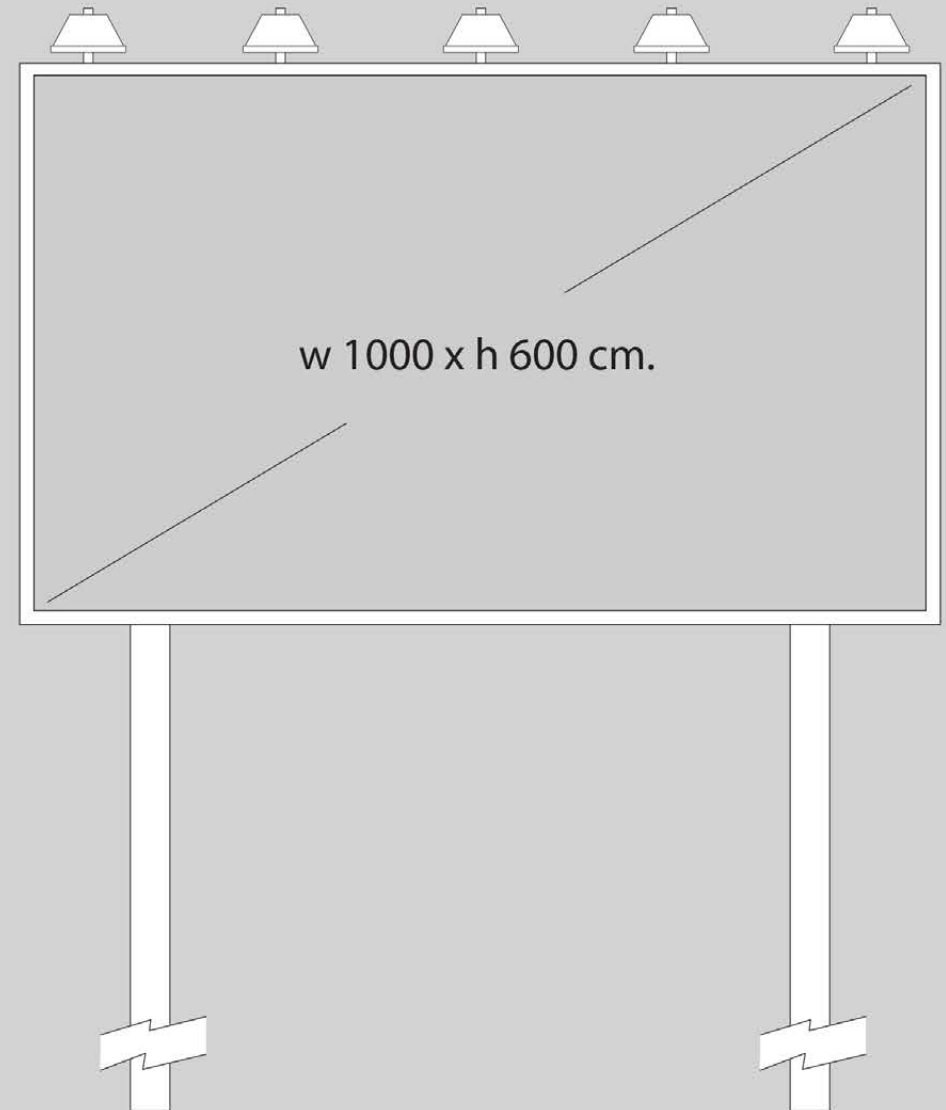

SIGNAGE

ADVERTISING BOARD

Billboard Expressway

Quantity : 3 boards (x 2 sides)

Code : MF

Size : w 20 x h 10 metres

LOADING IMPACT CHALLENGER EXPRESSWAY BILLBOARD

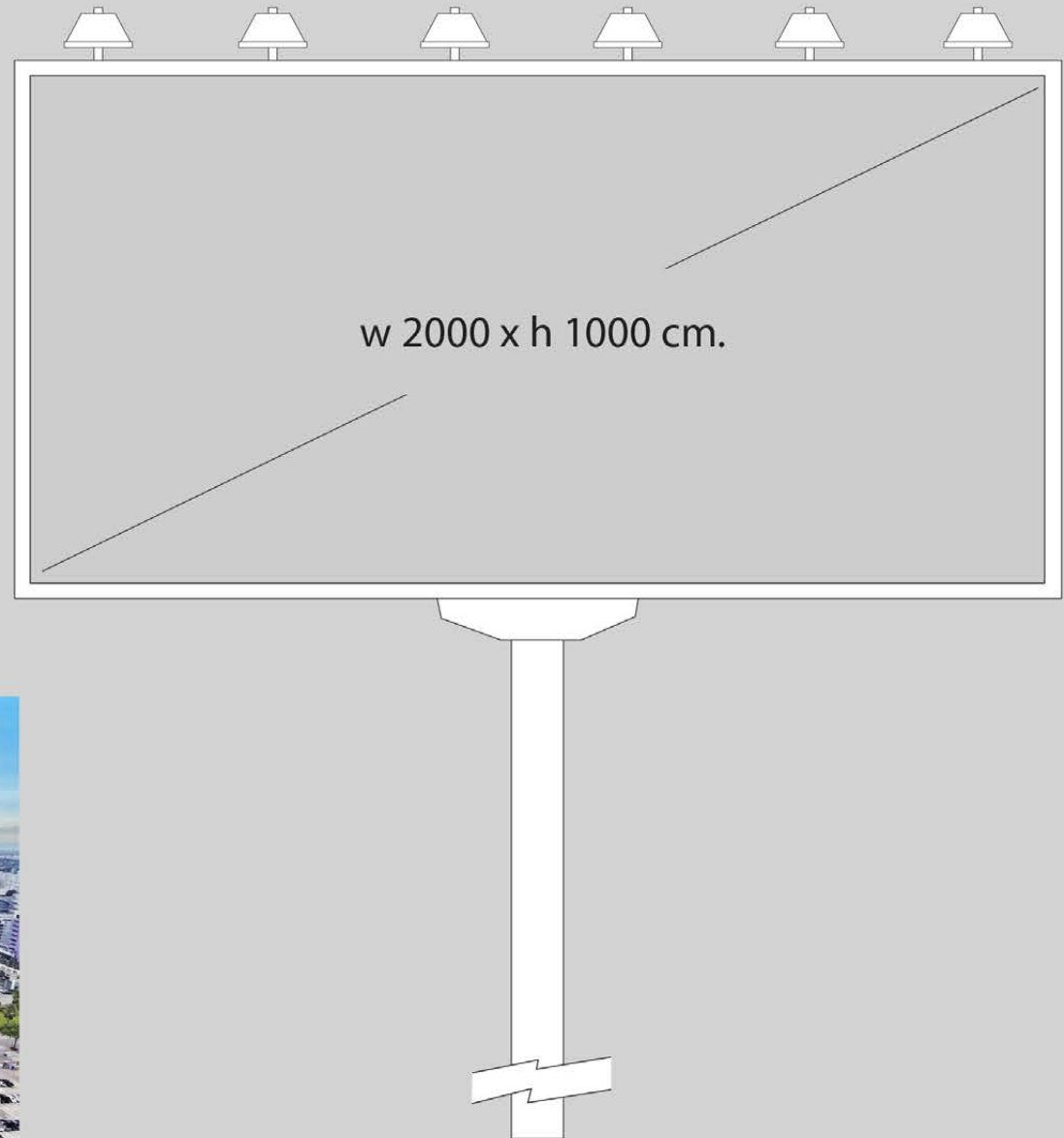

SIGNAGE

ADVERTISING BOARD

IMPACT Exhibition Hall 9 / Banner (Outdoor)

Size : w 10.6 x h 8.9 metres

Code : MG

AMBER wall / Banner (Outdoor)

Size : w 10.2 x h 4 metres

Code : MH

Quantity : 2 Boards



ADVERTISING SIGNAGE

LED Wall (OUTSIDE)

LED at IMPACT
Forum- Entrance 1



Size : w 1,920 x h 1,152 pixels

Quantity : 1 units

Media : DVD format , AVI , MPEG4 , WMV

SIGNAGE

LED Wall and Digital TV

LED - Link bridge - The Portal to IMPACT Challenger



Size : w 1,366 x h 192 pixels

Quantity : 1 units (x2 Side)

Media : DVD format , AVI , MPEG4 , WMV

SIGNAGE

LED Wall and Digital TV

LED CUBIC



Size : w 1024 x h 1080 pixels

Quantity : 1 units (2 Sides)

Media : DVD format , AVI , MPEG , WMV

SIGNAGE

LED Wall and Digital TV

LED Royal Jubilee Ballroom

(Outdoor/IMPACT Challenger1)



Size : w 576 x h 288 pixels

Quantity : 1 units

Media : DVD format , AVI , MPEG4 , WMV

SIGNAGE

LED Wall and Digital TV

LED The Portal (Totem)



Size : w 324 x h 648 pixels

Quantity : 1 units

Media : DVD format , AVI , MPEG4 , WMV

SIGNAGE

LED Wall and Digital TV

SKY ENTRANCE - LED (Outdoor)

IMPACT CHALLENGER

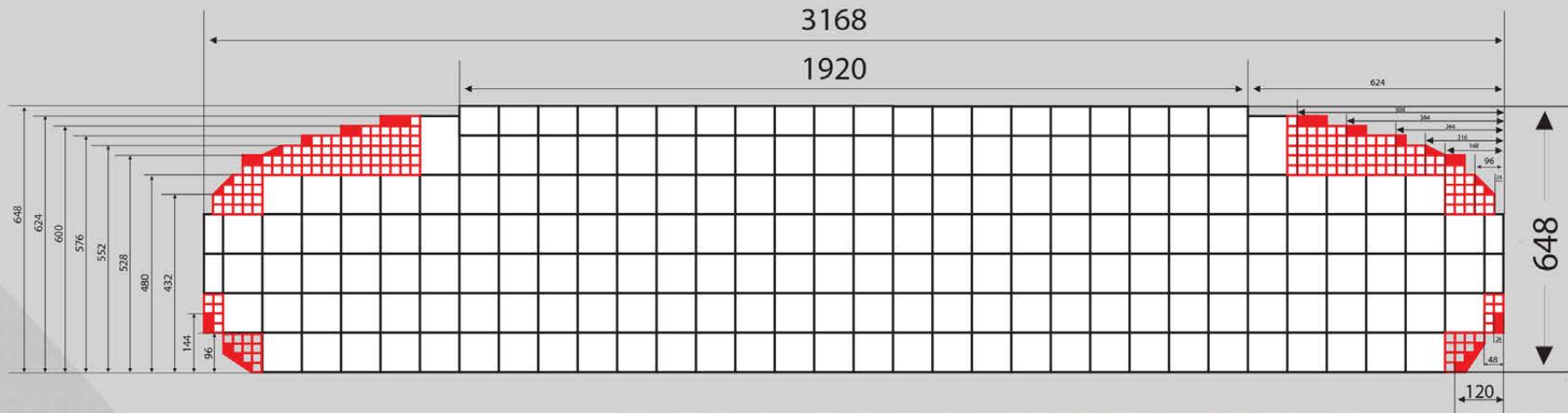

Size : w 3,168 x h 648 pixels

Quantity : 1 units

Media : DVD format , AVI , MPEG4 , WMV

SIGNAGE

LED Wall and Digital TV

Sky Entrance - Lobby LED (Indoor)

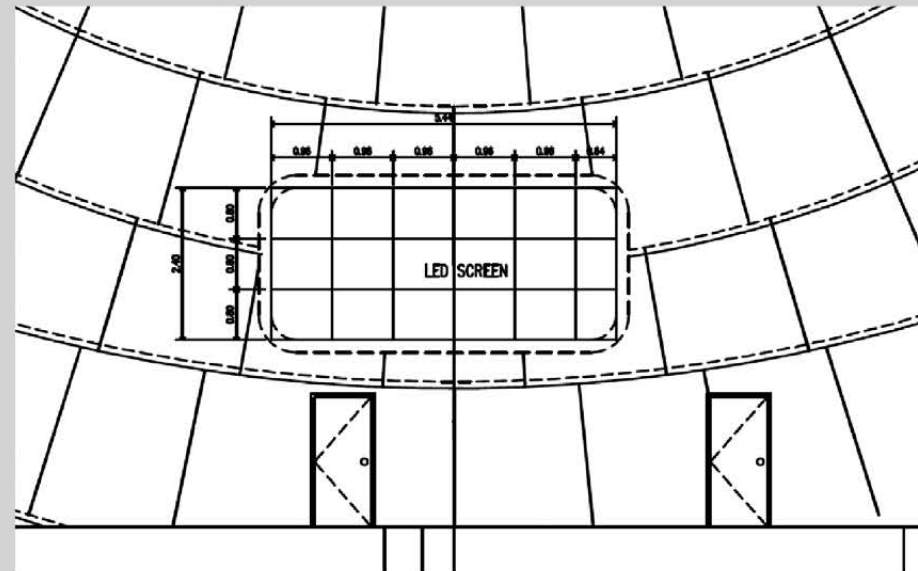

Size : w 544 x h 240 pixels

Quantity : 1 units

Media : DVD format , AVI , MPEG4 , WMV

SIGNAGE / BANGKOK LAND

ADVERTISING BOARD

1.1 Under Link Bridge / Advertising Banner

1.2 Billboard



**IBIS HOTEL TO
IMPACT FORUM**

1.1 Under Link Bridge / Advertising Banner

Size : w 200 x h 400 cm.

Media : Vinyl Inkjet

Quantity : 67 units



**IBIS HOTEL TO
IMPACT FORUM**



**Cheang Wattana - P1
View from Lak-Si**

1.2 Billboard Size : w 20 x h 10 Meters
Media : Vinyl Inkjet
Quantity : 3 units



**TIWANON - P1
View from Bang Poon**



**TIWANON - P1
View from Pak Kred**

SIGNAGE / BANGKOK LAND

LED Advertising P1 PYLON



Cheang Wattana - P1
View from Pak Kred

Size : w 4000 x h 2000 pixels
Quantity : 1 units
Media : DVD format , AVI , MPEG , WMV

MT02 LED Advertising Stair Cage



LED Resolutions : w 832 x h 320 pixels



VINYL INKJET

LBV01 : w 13.7 x h 5.64 metres
LBV01 : w 9.6 x h 9.2 metres

SIGNAGE / BANGKOK LAND P1 LONG BOARD (VINYL)

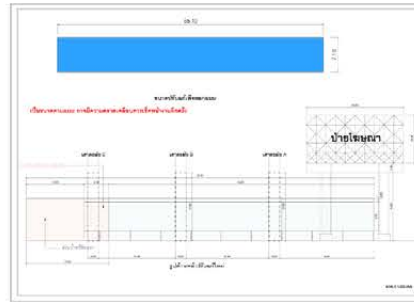

BANGKOK LAND / P1 Chaeng Wattana Road / Long Billboard

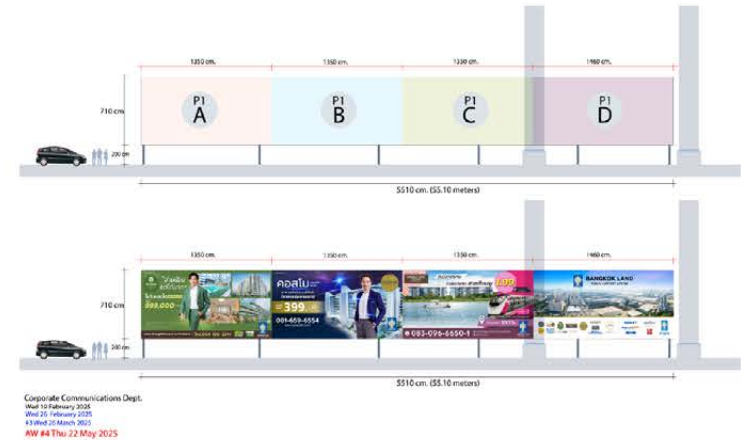

Specifications:

- Vinyl Inkjet 1400 dpi. outdoor
- วัสดุประเภท ฝ้าใบและหมักพิมพ์ 3 D
- ติดตั้งห่างจาก
- พิมพ์อาคารตึก P1/A, P1/B, P1/C, P1/D (สำหรับการเปลี่ยนอาคารตึกครั้งต่อไป สามารถเปลี่ยนทีละชิ้นได้)

P1 A

“จ่ายน้อย แต่ได้มาก”
โมริ คอนโด เมืองทองธานี
เริ่ม 999,000 บาท
www.bangkokland.co.th/mori | โทร. 064-180-2244

P1 B

คอสมอ ออฟฟิศ พาร์ค
อาคารสำนักงานให้เช่า
ใจกลางเมืองทองธานี
เริ่มต้นเพียง 399.- บาท / ตร.ม.
081-659-6554
www.cosmooffice.com

P1 C

DOUBLE LAKE
สละทสบาย
ใกล้รถไฟฟ้า สายสีชมพู
เริ่มต้นเพียง 1.99 ล้านบาท
จองฟรี 500 บาท
ที่จอดรถ 100%
083-096-6650-1
www.bangkokland.co.th/doublelake

P1 D

BANGKOK LAND
PUBLIC COMPANY LIMITED
Logos: Beehive, Impact, Novotel, Ibis, MSM, etc.

HOTEL

NOVOTEL BANGKOK IMPACT

NOVOTEL

BANGKOK IMPACT

PANTONE
2736 C

BEST BANGKOK HOTEL IN MUANG THONG THANI

This contemporary 4-star hotel in Bangkok has over 380 spacious rooms and suites. Novotel Bangkok Impact offers functional facilities and services for all guests. Including a swimming pool, fitness center, laundry service, etc. Whether working, traveling, or searching for a place to relax. We are at your service.

Novotel Bangkok is easily accessible to Don Muang Airport. As a result, It is only 12 kilometers or a 15-minute drive from the hotel. Also, Easy to drive by expressway to Suvarnabhumi International Airport within an hour. Moreover, You can reach the heart of Bangkok in just 30 minutes. There are shopping malls and attractive places near the hotel including the Rangsit area, Bangkok University, and Thammasat University.

- 145°F Grill & Bar
- The Square
- 94Bar
- In Balance by Novotel (Spa & Fitness)

 <https://novotelbangkokimpact.com>

 NovotelIMPACT

 novotelbangkokimpact

 www.youtube.com/@novotelimpact

 @novotelimpact

 +66 2 833 4888



HOTEL

IBIS BANGKOK IMPACT



ibis Bangkok IMPACT



Discover one of the best of Muang Thong Thani at ibis Bangkok IMPACT. This ibis in Bangkok is perfectly located at the heart of the largest exhibition centre in Thailand. As your best choice of stay, this 3 star hotel in Bangkok is just a few steps away from IMPACT Arena when you plan to participate on your next event or concert. It offers international standard at the best price you cannot find elsewhere.

- Groove & Greens Café
- TASTE Restaurant

- 🌐 <https://www.ibisbangkokimpact.com>
- 📘 [ibisBangkokImpact](#)
- 📷 [ibisimpact](#)
- 📺 www.youtube.com/@ibisBangkokIMPACT
- 💬 [@ibisimpact](#)
- ☎️ +66 (0) 2 011 7777



IMPACT
MUANG THONG THANI

IMPACT CORPORATE IDENTITY

Corporate Communications Department
VERSION UPDATE : @JUNE 2026

